



BOOM TRUCK

Puck Lead Pump

Next-level power and performance, the Boom Truck is engineered for versatility and designed to attack the task at hand.

BOOM TRUCK FEATURES:

- CAT C13B (577 HP) Engine
- Cornell 6819MPC Main Pump- direct driven
- Cornell 10NNWH Boom Pump- hydrostat driven
- 70' horizontal reach
- 3,500 GPM capacity at 125 PSI
- 8" pipe used at waterway
- International, Freightliner, Peterbilt and other chassis configurations available

LIGHTSPEED FEATURES:

- Automated pump control
- Auto-throttle control of engine speed
- Accessible from any connected web-enabled device
- Remote start from anywhere
- Customizable operating parameters
- Live working pressure readings
- Helps you remedy situation as they arise
- Maintenance record recorded



- ✓ Near real time pump control, accessible anywhere from nearly any device
- ✓ 99% online equipment accessibility uptime
- ✓ Redesigned web interface allows for quick navigation and operator control
- ✓ Additional features include site-mapping, pump reporting, customizable maintenance notifications, and more
- ✓ Most robust wireless pump control on the market



AMERICAN MADE TOUGH.™

Contact us today: 712.655.9200 · puck.com/industrial-equipment



BOOM TRUCK



	U.S.	Metric
Vertical Reach (ft.-in. - m.)	59' 2"	18
Horizontal Reach (ft.-in. - m.)	70' 3"	21.4
Boom Primary Section (ft.-in. - m.)	21' 2"	6.5
Boom Secondary Section (ft.-in. - m.)	16' 8"	5.1
Boom Tertiary Section (ft.-in. - m.)	16' 5"	5.0
Boom Quaternary Section (ft.-in. - m.)	16' 8"	5.1
Outrigger Spread Front (Side to Side)	20' 5"	6.2
Outrigger Spread Rear (Side to Side)	20' 4"	6.2
Outrigger Spread (Front to Back)	14' 0"	4.2
Outrigger Loading Front (lbs. - kg)	30,500	13,864
Outrigger Loading Rear (lbs. - kg)	27,500	12,500
Boom Piping (in. - mm)	8"	203
Hydraulic Capacity (gal. - L)	30	114
Fuel Capacity (gal. - L)	300	1,136

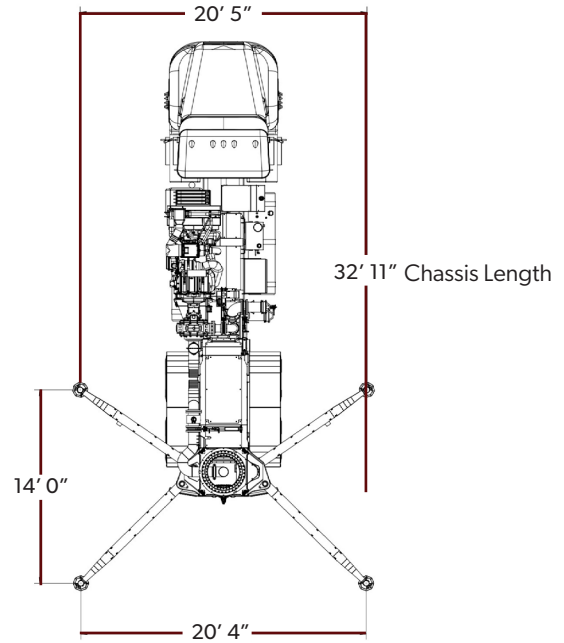

BOOM TRUCK FEATURES

- 4 Section Z-fold boom
- 180° clockwise and counterclockwise boom rotation
- Hydraulic folding and jacking outriggers

