



# FORCE FEED TRAILER



Force Feed Trailer 4500-45

***A New Approach to Bringing Water to the Fire***





# FF4500-45

## Attack the task at hand with the Force Feed Trailer

Effective fire suppression begins at the source of water. Utilizing the Puck Fire Force Feed products, flow rates over 4,000 GPM are quickly and safely achieved without deploying floating submersible pumps and hydraulic lines. The trailer mounted FF4500-45 creates flow rates up to 4,500 GPM through a 45' boom and mounted submersible pump.

### APPLICATIONS OF USE

Move water quickly from your storage or water source with the versatile power of the Puck Fire Force Feed Trailer. Built solid with hydrostat controls and designed for ease of deployment, our Force Feed pump brings a higher level of performance for pumping water. The knuckle boom with remote control has a horizontal length of 45' to reach out, down, up and over to get to your source of water.

### FORCE FEED TRAILER FEATURES



#### FAST DEPLOYMENT

- ✓ Wireless remote boom control
- ✓ Electric over hydraulic downriggers



#### SETUP VERSATILITY

- ✓ 45' boom reach
- ✓ Knuckle boom design



#### ADJUSTABLE FLOW

- ✓ Up to 4,500 GPM
- ✓ 8" boom pipework



#### PRECISION CONTROL

- ✓ Hydraulic gate control via LightSpeed
- ✓ Accurate flow readings via 8" KROHNE flow tube



#### MAXIMUM RUN TIME

- ✓ Up to 14 hours
- ✓ 360 gallon diesel & 24 gallon DEF capacity



#### MAXIMUM DISPLACEMENT

- ✓ 577 HP pump engine
- ✓ 8NHG19 Cornell pump with 19" impeller

## A New Approach to Bringing Water to the Fire



# Force Feed Trailer Specifications

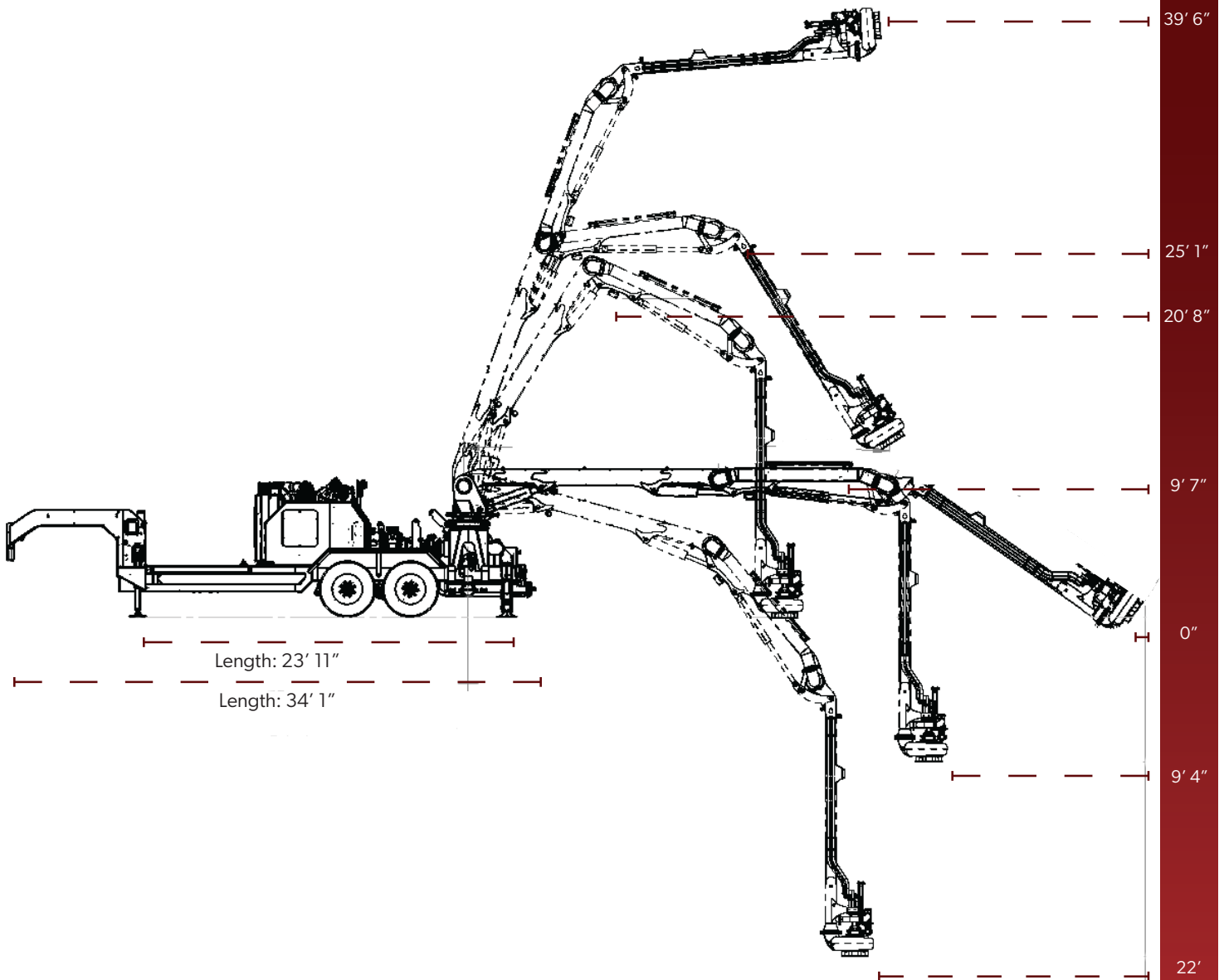

View the entire lineup at [puck.com/puck-fire](http://puck.com/puck-fire) to learn more.

**A New Approach to Bringing Water to the Fire**







# LIGHTSPEED

## AUTOMATED PUMP CONTROL

At Puck Fire, our equipment is designed to efficiently and safely move water to the fire scene. LightSpeed brings real-time asset control to your fingertips. Monitor and adjust engine speeds, open and close valves, and make real-time, data-based decisions to ensure everyone on your crew goes home safely at the end of the day.

We don't just build the best pumps — we create the hardware and software that helps them keep that status. LightSpeed is the only control system on the market that offers full site-mapping, in-depth pump diagnostics and insight, allowing you to have remote monitoring and control of your pumps in real time. This technology comes standard on all Puck pumps, so all your pumps will be protected and monitored by the watchful eyes of this powerful platform. Regulate pressures and add another layer of safety without adding more people, through LightSpeed's advanced pump protection technology.



## LIGHTSPEED FEATURES

- ✓ Real-time asset control
- ✓ Intuitive, web-based operating platform
- ✓ Customizable operating parameters
- ✓ Auto-throttle control of engine speed
- ✓ Warning indicator for machine vitals and operating parameters
- ✓ Accessible for any connected, web-enabled device
- ✓ Open and close valves remotely



*A New Approach to Bringing Water to the Fire™*

