



PERFORMANCE... UNMATCHED.



BT5770 Boom Truck

Fast setup time and more gallons.

Next-level power and performance, the Boom Truck is engineered for versatility and designed to attack the task at hand.

BOOM TRUCK FEATURES

- ✓ CAT C13B-577 HP Engine
- ✓ Cornell 6819MPC Main Pump - Direct driven
- ✓ Cornell 10NNWH Boom Pump - Hydrostat driven
- ✓ 70' Horizontal reach
- ✓ 3,500 GPM capacity at 125 PSI
- ✓ 8" Pipe used at waterway
- ✓ International, Freightliner, Peterbilt and other chassis configurations available

Call **712.655.9200** to inquire now.



LIGHTSPEED™

- ✓ Near-instant pump control, accessible anywhere from almost any device
- ✓ 99% uptime guarantee
- ✓ Now with improved, user-friendly navigation
- ✓ Full site-mapping and detailed pump diagnostics



Boom Truck Specifications



	U.S.	Metric
Vertical Reach (ft.-in. - m.)	59' 2"	18
Horizontal Reach (ft.-in. - m.)	70' 3"	21.4
Boom Primary Section (ft.-in. - m.)	21' 2"	6.5
Boom Secondary Section (ft.-in. - m.)	16' 8"	5.1
Boom Tertiary Section (ft.-in. - m.)	16' 5"	5.0
Boom Quaternary Section (ft.-in. - m.)	16' 8"	5.1
Outrigger Spread Front (Side to Side)	20' 5"	6.2
Outrigger Spread Rear (Side to Side)	20' 4"	6.2
Outrigger Spread (Front to Back)	14' 0"	4.2
Outrigger Loading Front (lbs. - kg)	30,500	13,864
Outrigger Loading Rear (lbs. - kg)	27,500	12,500
Boom Piping (in. - mm)	8"	203
Hydraulic Capacity (gal. - L)	30	114
Fuel Capacity (gal. - L)	300	1,136

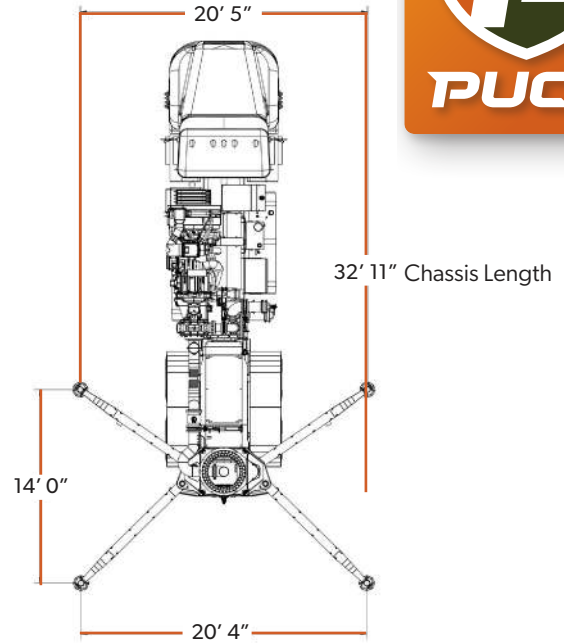

BOOM TRUCK FEATURES

- ✓ 4 Section Z-Fold Boom
- ✓ 180° Clockwise and Counterclockwise Boom Rotation
- ✓ Hydraulic Folding and Jacking Outriggers

